

Minamiku Art Next Exhibition: Call for Entries

Fukuoka City's Minami Ward, in collaboration with universities and junior colleges within the ward, has been promoting the Minamiku Art Next project since 2023. The project aims to support young artists who will be leading the way in the future.

This year, an event to exhibit works by students and residents of Minami Ward will be held on November 2nd and 3rd, coinciding with school festivals in neighboring universities. We are calling for submissions from students and young artists who are eager to collaborate with us in enlivening Minami Ward through art. We look forward to receiving many submissions!

(Overview of the Event)

Date: November 2nd (Sat) and 3rd (Sun, public holiday), 2024

* The venue will be ready for installation on November 1st (Fri).

Venue: Fukuoka City Minami Civic Center/ Shiobaru Music and Theater Practice Center
Large/Medium/Small Rehearsal Halls, Audio-Visual Room, Meeting Room

(Submission Guidelines)

◆ Works eligible for submission

Works in the fields of painting, three-dimensional works, graphic design, digital art, photography, crafts, video, fashion, and theater.

◆ Application period

August 1 (Thu) to September 30 (Mon)

* Works submitted at 11:59 pm on September 30 are deemed valid.

* The secretariat will check the contents of your work and contact you by October 15 (Tue) to let you know whether it is eligible to exhibit.

◆ Eligible applicants

- Students attending universities, junior colleges, and technical colleges located in Minami ward.
- University, junior college, or technical college students residing in Minami ward.
- Those aged between 18 and 29 who either reside in or commute to Minami ward.

* Works by individuals and groups are both accepted.

* You can be a professional or an amateur artist.

◆ How to apply

Fill out and submit the application form on the Minami ward website.

* Photos of your work, or materials that will give an idea of the completed work must be attached to the application.

* The file you use to submit your data must include the following:

1. Your name
2. Number of your work (If you are submitting one item, it should be numbered 01; if you are

submitting more than one item, number them 01, 02 and so on.)

3. Title of your work

4. Year your work was completed

5. Size of your work (length, width, and height, including the unit)

6. Materials used

7. Whether you are submitting the work as an individual or a group

(If you are submitting the work as a group, write the group name.)

e.g.: Tarō Minamiku_01_Tarō's Art_2023_50cmx50cm_oil painting_individual

Place an underscore in between the items.

*Postal submissions are not accepted.

*The link to the Minami ward website

(Minamiku Art Next Exhibition Event Calling for Entries)

https://www.city.fukuoka.lg.jp/minamiku/k-shinko/charm-event/minamiku_art_next_2024_sakuhinboshuu.html

*Or you can go to the Minamiku Art Next website to find the link to the application form.

◆ Number of works that can be submitted

Multiple submissions are accepted. However, not all of your works may be exhibited.

◆ Fee for exhibiting your work: None

◆ Miscellaneous

- You may submit works that are incomplete, but you are required to submit materials that will give an idea of the completed work. The secretariat may contact you to ask the progress of your work.
- Exhibits may be put on sale but please consult us beforehand. The secretariat will not be responsible for any troubles related to the sales of your work.

◆ Notes on installing and removing your work, rehearsal, and the exhibition

- You must install your works on November 1 (Fri) and remove them between 4 pm and 8 pm on November 3 (Sun), after the conclusion of the event. You must cover the cost for installing and removing your works. You must also bring your own equipment for installation and removal. We will not be responsible for any loss or damage occurring while your work is being moved to the exhibition site.

*Details on the installation and removal, including instructions and timing, will be sent via email between mid and late October.

- Rehearsals for video works and theatrical acting are scheduled for November 1 (Fri), between 12 noon and 8 pm. Details regarding the rehearsal will be provided separately, between mid and late October.
- You are responsible to manage your booth and your exhibits, and secure safety of visitors to your booth. You are also responsible for your personal belongings, including valuables, and for insuring your own exhibits.

<How to exhibit your works>

- The secretariat will provide you with a booth or space for your exhibits. The location will be informed separately.

Image of the booth to display paintings, photos, etc.

Maximum size of the booth
H: 2,000mm*W: 2,000mm

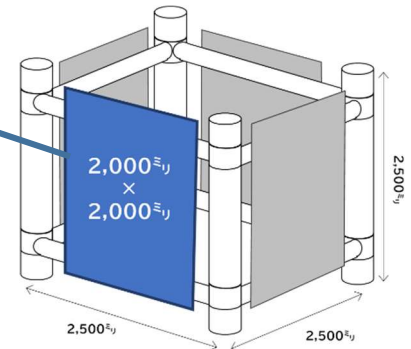

- You must bring your own hanging wires and fixtures. Fixtures that require drilling holes in the walls or other parts of the venue may not be used.
- You must display your work within your booth or space.
- If you have any questions regarding the displaying of your work, please consult the secretariat.

<Judging and awards>

- There are no awards for the exhibits.
- A gallery tour with art planner Kazuki Saito (director of SPONGE Co. Ltd.) and others to view the exhibited works will take place during the exhibition period.

<On copyrights>

- Do not violate copyrights, such as using another person's work without permission.
- If you use free or out-of-copyright materials, please indicate the source in the application form.
- If you wish to use another person's work (material) in your work, please obtain permission to do so in advance. Also, please indicate on the application form where you obtained permission from.
- The organizer will not be held responsible for any issues related to copyright or privacy infringement.
- The copyrights and other intellectual property rights to your works belong to you. However, the organizer reserves the right to use your name and your works on the Minamiku Art Next website, social media platforms, mass media, and internet to promote this and other related events. The organizer also reserves the right to use your name and works at events that align with the purpose of this event.

◆ Privacy Policy

Personal information provided on the application form will be handled as follows:

(Purpose of using such information)

1. To contact you regarding your work
2. To provide you with information from the organizer
3. For publication of individual and group names on the sponsor's website, in PR magazines and other print media, and on the Internet.

(Information disclosure)

We will not provide or disclose personal information to third parties except in response to a

request for disclosure of information from judicial, administrative, or similar agencies in accordance with laws and regulations.

(Entry requirements)

Please check the following entry requirements for each category before submitting your work.

[For two-dimensional artwork]

This is a category for painting, graphic design and photography.

- Submit an image of the work (file size: 10 MB or less / file format: jpg, png). If your work is not complete, please submit a production schedule and a material such as rough sketches to show the specific content of your work.
- Indicate the size of your artwork.
- Maximum size is 2,000 mm (length) x 2,000 mm (width) (Contact the Secretariat in advance if your artwork exceeds this size.)
- Framing is optional. If framed, the size must include the frame.
- Glass is not permitted as it might break. Acrylic is acceptable.
- Easels to hold or materials to hang your work must be strong enough to support your artwork securely.

[For three-dimensional artwork]

This is a category for crafts and fashion (e.g. exhibitions using mannequins).

- Submit an image of the work (file size: 10 MB or less / file format: jpg, png). If your work is not complete, please submit a production schedule and a material such as rough sketches to show the specific content of your work.
- Indicate the size of your artwork.
- Maximum size is 2,000 mm (length) x 2,000 mm (width) x 2,000 mm (depth) (Contact the Secretariat in advance if your artwork exceeds this size.)
- You must be able to carry your artwork in and out of the exhibition venue.

[For digital art and videos]

This is a category for still images (e.g. still images produced by computer graphics, image processing, etc.), moving images (moving images such as animations produced by computer graphics, moving image processing, or other digital technology), and interactive art (works that incorporate interactivity through the application of media technology).

● Still image

- Submit an image of the work (file size: 10 MB or less / file format: jpg, png). If your work is not complete, please submit a production schedule and a material such as photos and videos to show the specific content of your work.
- The work must be finished with wooden panels or as a simple display (exhibition panels,

affixed on a Styrofoam board affixed, etc.).

- File format of the work: jpg, png
- Indicate the size of the output.
- Maximum size is 2,000 mm (length) x 2,000 mm (width) (Contact the Secretariat in advance if your artwork exceeds this size.)
- If your artwork is made up of more than one image, submit an image of all images side by side.
- If your artwork is made up of more than one image, indicate the size of all images laid out together. (e.g. 3m in length and 5.5m in width)

- Video

- Submit a digest version of the film (within 3 minutes / file format: mp4) that shows the content of the work. If the work is not completed, please submit a production schedule and a thumbnail or other similar materials to show specific details.

*We will contact you about the data for a digest version once you have applied. Please submit it in the specified manner.

- Indicate the file format of the work to be exhibited.
- Submit your work on a DVD, BD or USB memory stick or similar media with the following information, placed in a case or similar container to prevent it from being lost or scattered. Indicate: 1_Title of work_name of creator with number (e.g. Super Short (1)).
- The file name of the submitted data should be 'title of work_name of creator'.

- Interactive art

- Submit a short introductory film (within 3 minutes / file format: mp4) that shows how the work operates or explains its functions and methods of operation. If the work is not completed, please submit a production schedule and videos or photos to show specific details.

*We will contact you about the data for an introductory film once you have applied. Please submit it in the specified manner.

- Indicate the size of the space needed for the exhibition.
- Maximum size is 2,000 mm (length) x 2,000 mm (width) x 2,000 (height) (Contact the Secretariat in advance if your artwork exceeds this size.)

[For installation artwork]

This is a category for space-based installation artwork.

- Submit an image of the work (file size: 10 MB or less / file format: jpg, png) that shows the content of your work. If your work is not complete, please submit a production schedule and videos or images that shows specific content of your work.
- Indicate the size of the space needed for the exhibition.
- Maximum size is 2,000 mm (length) x 2,000 mm (width) x 2,000 (height) (Contact the Secretariat in advance if your artwork exceeds this size.)

【For theatre productions】

This is a category for theatrical performances to take place in some of the spaces in the large rehearsal hall of the Shiobaru Music and Theater Practice Center, or in the medium rehearsal hall.

- Due to space and equipment constraints, this year's event will be limited to the staging of small-scale productions, readings and recitations (no large-scale productions will be staged).
- Performance duration: from 3 to 60 minutes.
- Indicate the size (space) of the stage to be used.

*If you use lighting, you must bring your own lighting, unless it is available at the facility.

Inquiries:

Minamiku Art Next Secretariat

Planning Promotion Section, General Affairs Department, Minami Ward Office

E-mail: kikaku.MWO@city.fukuoka.lg.jp

Tel: 092-559-5017